

DETAILS OF SHEARING EQUIPMENT

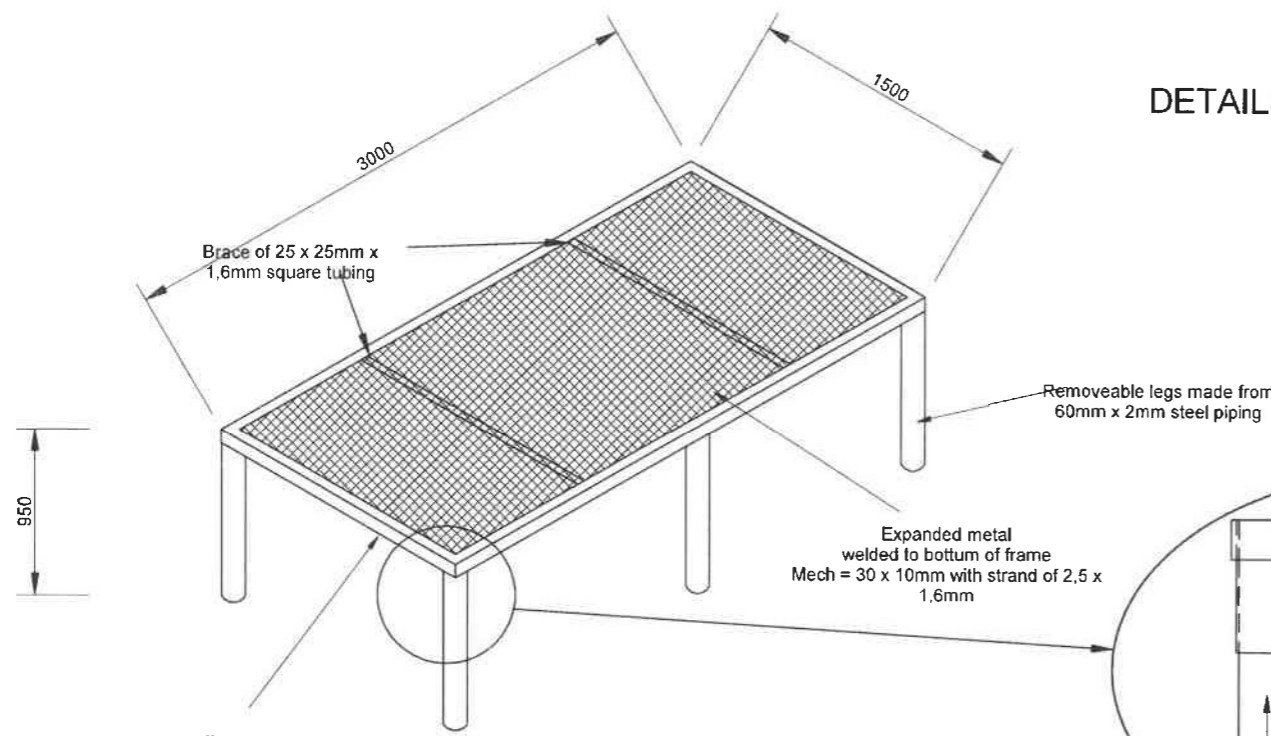

WOOL SORTING TABLE

Not to scale

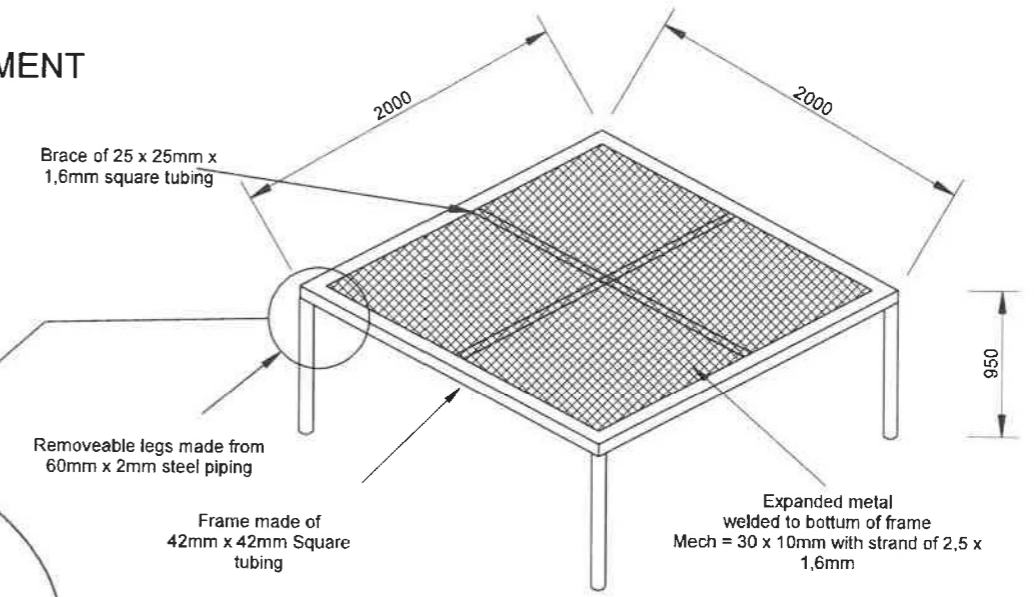

PIECE PICKING TABLE

Not to scale

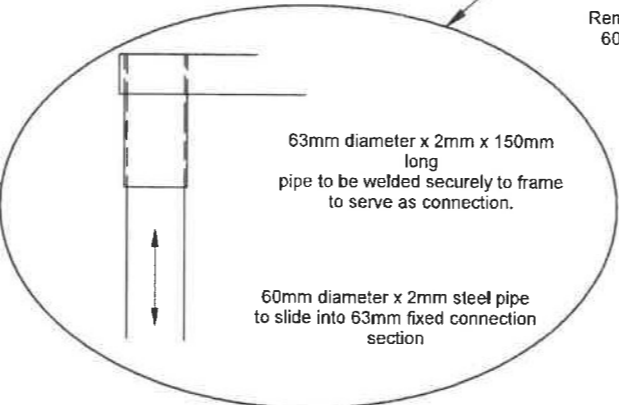

50mm x 50mm wire mesh. Securely attached to frame

8 Woolbins to be provided, with sharing sections (not 8 stand-alone) bins.

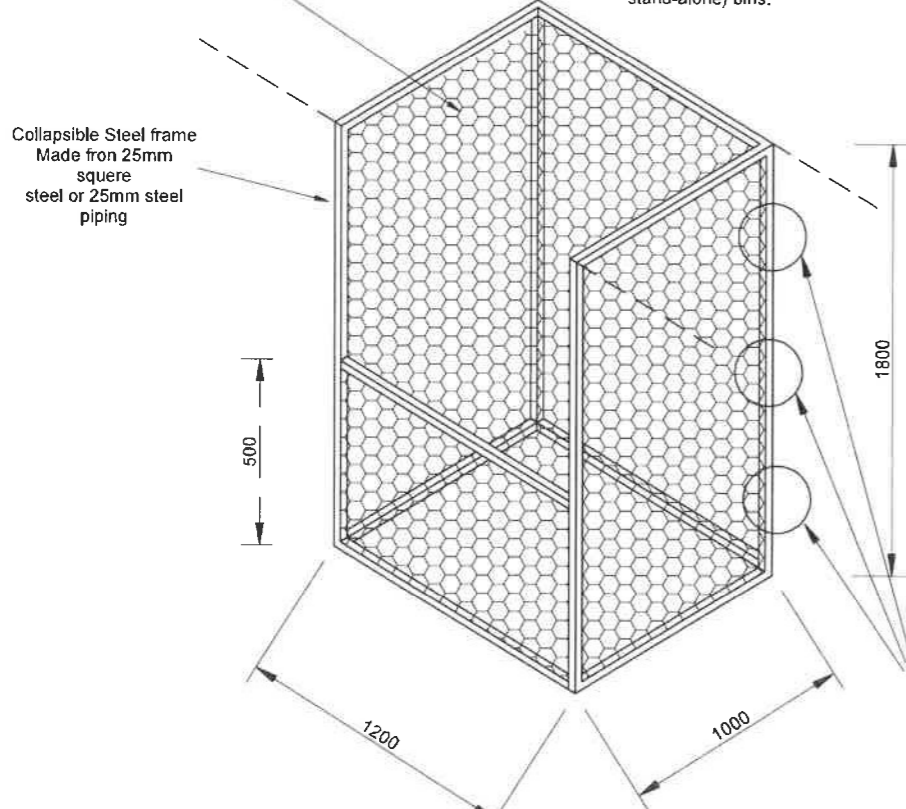

WOOL BIN

Not to scale

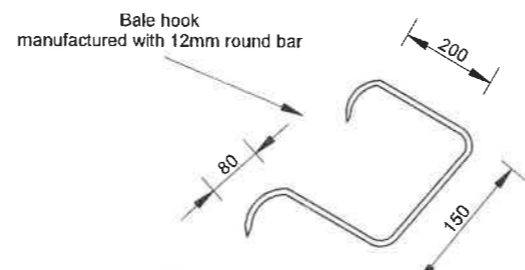

BALE HOOKS

Not to scale

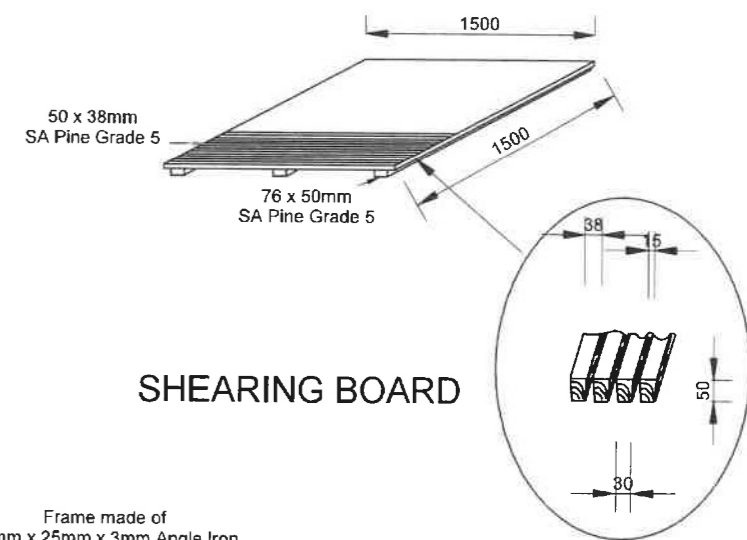

SHEARING BOARD

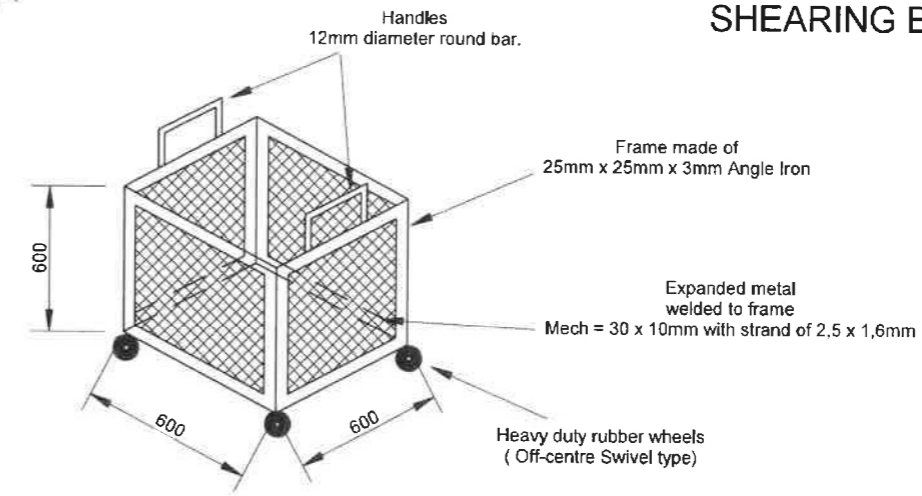

WOOL BASKETS

Not to scale

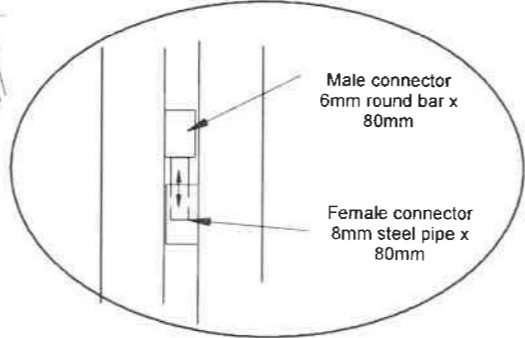

NO.	SPECIAL NOTES:	DEPARTMENT OF RURAL DEVELOPMENT AND AGRARIAN REFORM PROVINCE OF THE EASTERN CAPE	SHEARING EQUIPMENT	SCALE	INDEX NO.
		ENGINEERING SERVICES PRIVATE BAG X015 DOHNE ADJ STUTTERHEIM 4930	SHEARING EQUIPMENT	NTS	SCMM00/26/01
			SHEARING EQUIPMENT	A3 ORIGINAL	PLAN NO. SHEET 1 OF 1

JPJ KOCH
(CHIEF ENGINEER)

DECEMBER 2020
(DATE APPROVED)